



Operating Instructions and Parts Manual 20-inch Variable Speed Drill Presses

Models: J-2221VS, J-2223VS, J-2232AC, J-2234AC



J-2221VS
J-2223VS



J-2232AC
J-2234AC

JET
427 New Sanford Road
LaVergne, Tennessee 37086
Ph.: 800-274-6848
www.jettools.com

Part No. M-354221
Revision D1 08/2015
Copyright © 2015 JET

Warranty and Service

JET warrants every product it sells against manufacturers' defects. If one of our tools needs service or repair, please contact Technical Service by calling 1-800-274-6846, 8AM to 5PM CST, Monday through Friday.

Warranty Period

The general warranty lasts for the time period specified in the literature included with your product or on the official JET branded website.

- JET products carry a limited warranty which varies in duration based upon the product. (See chart below)
- Accessories carry a limited warranty of one year from the date of receipt.
- Consumable items are defined as expendable parts or accessories expected to become inoperable within a reasonable amount of use and are covered by a 90 day limited warranty against manufacturer's defects.

Who is Covered

This warranty covers only the initial purchaser of the product from the date of delivery.

What is Covered

This warranty covers any defects in workmanship or materials subject to the limitations stated below. This warranty does not cover failures due directly or indirectly to misuse, abuse, negligence or accidents, normal wear-and-tear, improper repair, alterations or lack of maintenance. JET woodworking machinery is designed to be used with Wood. Use of these machines in the processing of metal, plastics, or other materials outside recommended guidelines may void the warranty. The exceptions are acrylics and other natural items that are made specifically for wood turning.

Warranty Limitations

Woodworking products with a Five Year Warranty that are used for commercial or industrial purposes default to a Two Year Warranty. Please contact Technical Service at 1-800-274-6846 for further clarification.

How to Get Technical Support

Please contact Technical Service by calling 1-800-274-6846. **Please note that you will be asked to provide proof of initial purchase when calling.** If a product requires further inspection, the Technical Service representative will explain and assist with any additional action needed. JET has Authorized Service Centers located throughout the United States. For the name of an Authorized Service Center in your area call 1-800-274-6846 or use the Service Center Locator on the JET website.

More Information

JET is constantly adding new products. For complete, up-to-date product information, check with your local distributor or visit the JET website.

How State Law Applies

This warranty gives you specific legal rights, subject to applicable state law.

Limitations on This Warranty

JET LIMITS ALL IMPLIED WARRANTIES TO THE PERIOD OF THE LIMITED WARRANTY FOR EACH PRODUCT. EXCEPT AS STATED HEREIN, ANY IMPLIED WARRANTIES OF MERCHANTABILITY AND FITNESS FOR A PARTICULAR PURPOSE ARE EXCLUDED. SOME STATES DO NOT ALLOW LIMITATIONS ON HOW LONG AN IMPLIED WARRANTY LASTS, SO THE ABOVE LIMITATION MAY NOT APPLY TO YOU.

JET SHALL IN NO EVENT BE LIABLE FOR DEATH, INJURIES TO PERSONS OR PROPERTY, OR FOR INCIDENTAL, CONTINGENT, SPECIAL, OR CONSEQUENTIAL DAMAGES ARISING FROM THE USE OF OUR PRODUCTS. SOME STATES DO NOT ALLOW THE EXCLUSION OR LIMITATION OF INCIDENTAL OR CONSEQUENTIAL DAMAGES, SO THE ABOVE LIMITATION OR EXCLUSION MAY NOT APPLY TO YOU.

JET sells through distributors only. The specifications listed in JET printed materials and on official JET website are given as general information and are not binding. JET reserves the right to effect at any time, without prior notice, those alterations to parts, fittings, and accessory equipment which they may deem necessary for any reason whatsoever. JET® branded products are not sold in Canada by JPW Industries, Inc.

Product Listing with Warranty Period

90 Days – Parts; Consumable items
1 Year – Motors; Machine Accessories
2 Year – Metalworking Machinery; Electric Hoists, Electric Hoist Accessories; Woodworking Machinery used for industrial or commercial purposes
5 Year – Woodworking Machinery
Limited Lifetime – JET Parallel clamps; VOLT Series Electric Hoists; Manual Hoists; Manual Hoist Accessories; Shop Tools; Warehouse & Dock products; Hand Tools; Air Tools

NOTE: JET is a division of JPW Industries, Inc. References in this document to JET also apply to JPW Industries, Inc., or any of its successors in interest to the JET brand.

Table of Contents

Section	Page
Warranty and Service.....	2
Table of Contents.....	3
Warning.....	4
Machinery General Safety Warnings	4
General Electrical Cautions.....	5
Safety Instructions for Drill Presses	6
Introduction	6
General Specifications	7
Hole centers in Base (all models).....	7
Operation and Set-Up	8
Securing the Base	8
Raising the Drill Head and Table.....	9
Electrical Connection	9
Operating Controls.....	10
Manual Speed Control (Models J-2221VS and J-2223VS).....	10
Inverter Speed Control (Models J-2232AC and J-2234AC)	10
Depth Indicator — All Models	11
Maintenance.....	11
Replacement of Drive Belt.....	11
Replacement of Motor	12
Lubrication.....	12
Adjustments	13
Table Adjustment	13
Radial Head Adjustment (All Models).....	13
Speed Pickup Adjustment (All Models)	13
Operating Precautions	13
Drilling Recommendations	14
Speeds for Drilling	14
Feeds for Drilling	14
Indication of Extreme Speeds and Feeds	14
Speeds for High Speed Steel Drills	14
Optional Equipment.....	15
Coolant System Installation.....	15
Replacement Parts.....	16
Exploded View – Drill Head – Manual Speed Control (J-2221VS and J-2223VS).....	17
Parts List – Drill Head – Manual Speed Control (J-2221VS and J-2223VS).....	18
Exploded View – Drill Head – Inverter Speed Control (J-2232AC and J-2234AC)	20
Parts List – Drill Head – Inverter Speed Control (J-2232AC and J-2234AC)	21
Exploded View – Spindle Components (All Models)	23
Parts List – Spindle Components (All Models)	23
Exploded View – Safety Shield Assembly (All Models).....	25
Parts List – Safety Shield Assembly (All Models).....	25
Exploded View – Table and Base (All Models)	26
Parts List – Table and Base (All Models)	27
Wiring Diagram – Models J-2221VS and J-2223VS	29
Wiring Diagram – Models J-2232AC and J-2234AC	30

Warnings

- Misuse of this machine can cause serious injury.
- For safety, machine must be set up, used and serviced properly.
- Read, understand and follow instructions in the Operating Instructions and Parts Manual which was shipped with your machine.

When setting up machine:

- Always avoid using machine in damp or poorly lighted work areas.
- Always be sure the machine support is securely anchored to the floor or the work bench.

When using machine:

- Always wear safety glasses with side shields (See ANSI Z87.1)
- Never wear loose clothing or jewelry.

- Never overreach—you may slip and fall.
- When servicing machine:**

- Always disconnect the machine from its electrical supply while servicing.
- Always follow instructions in Operating Instructions and Parts Manual when changing accessory tools or parts.
- Never modify the machine without consulting JET.

You—the stationary power tool user—hold the key to safety.

Read and follow these simple rules for best results and full benefits from your machine. Used properly, JET machinery is among the best in design and safety. However, any machine used improperly can be rendered inefficient and unsafe. It is absolutely mandatory that those who use our products be properly trained in how to use them correctly. They should read and understand the Operating Instructions and Parts Manual as well as all labels affixed to the machine. Failure in following all of these warnings can cause serious injuries.

Machinery General Safety Warnings

1. Always wear protective eye wear when operating machinery. Eye wear shall be impact resistant, protective safety glasses with side shields which comply with ANSI Z87.1 specifications. Use of eye wear which does not comply with ANSI Z87.1 specifications could result in severe injury from breakage of eye protection.
2. Wear proper apparel. No loose clothing or jewelry which can get caught in moving parts. Rubber soled footwear is recommended for best footing.
3. Do not overreach. Failure to maintain proper working position can cause you to fall into the machine or cause your clothing to get caught, pulling you into the machine.
4. Keep guards in place and in proper working order. Do not operate the machine with guards removed.
5. Avoid dangerous working environments. Do not use stationary machine tools in wet or damp locations. Keep work areas clean and well lit.
6. Avoid accidental starts by being sure the start switch is "OFF" before plugging in the machine.
7. Never leave the machine running while unattended. Machine shall be shut off whenever it is not in operation.
8. Disconnect electrical power before servicing. Whenever changing accessories or general maintenance is done on the machine, electrical power to the machine must be disconnected before work is done.
9. Maintain all machine tools with care. Follow all maintenance instructions for lubricating and the changing of accessories. No attempt shall be made to modify or have makeshift repairs done to the machine. This not only voids the warranty but also renders the machine unsafe.
10. Machinery must be anchored to the floor.
11. Secure work. Use clamps or a vise to hold work, when practical. It is safer than using your hands and it frees both hands to operate the machine.
12. Never brush away chips while the machine is in operation.
13. Keep work area clean. Cluttered areas invite accidents.
14. Remove adjusting keys and wrenches before turning machine on.

15. Use the right tool. Don't force a tool or attachment to do a job for which it was not designed.
16. Use only recommended accessories and follow manufacturer's instructions pertaining to them.
17. Keep hands in sight and clear of all moving parts and cutting surfaces.
18. All visitors should be kept at a safe distance from the work area. Make workshop completely safe by using padlocks, master switches, or by removing starter keys.
19. Know the tool you are using — its application, limitations, and potential hazards.

Familiarize yourself with the following safety notices used in this manual:

CAUTION This means that if precautions are not heeded, it may result in minor injury and/or possible machine damage.

WARNING This means that if precautions are not heeded, it may result in serious or even fatal injury.

General Electrical Cautions

This drill press should be grounded in accordance with the National Electrical Code and local codes and ordinances. This work should be done by a qualified electrician. The saw should be grounded to protect the user from electrical shock.

Wire sizes

Caution: For circuits which are far away from the electrical service box, the wire size must be increased in order to deliver ample voltage to the motor. To minimize power losses and to prevent motor overheating and burnout, the use of wire sizes for branch circuits or electrical extension cords according to the following table is recommended.

Conductor Length	AWG (American Wire Gauge) number	
	240 Volt lines	120 Volt lines
0-50 feet	No. 14	No. 14
50-100 feet	No. 14	No. 12
Over 100 feet	No. 12	No. 8

Safety Instructions for Drill Presses

1. All work shall be secured using either clamps or a vise to the drill press table. It is unsafe to use your hands to hold any workpiece being drilled.
2. Drill press head and table shall be securely locked to the column before operating the drill press. This must always be checked prior to starting the machine.
3. Always use the correct tooling. Tooling shall always be maintained and properly sharpened. All tooling must be run at the proper speeds and feeds as they apply to the job. Use only recommended accessories and follow those manufacturer's instructions pertaining to them. Tooling shall not be forced in to any work piece but fed according to the proper specifications. Failure to follow these instructions will not only ruin the tooling as well as the machine, but can cause serious injury.
4. Never brush away any chips while the machine is in operation. All clean up should be done when the machine is stopped.
5. Keep hands in sight. Do not put hands or fingers around, on, or below any rotating cutting tools. Leather safety gloves should be used when handling any sharp objects or cutting tools. See Figure A.
6. Always wear protective eye wear when operating, servicing or adjusting machinery. Eyewear shall be impact resistant, protective safety glasses with side shields complying with ANSI Z87.1 specifications. Use of eye wear which does not comply with ANSI Z87.1 specifications could result in severe injury from breakage of eye protection. Figure B.
7. When drilling in material which causes dust, a dust mask shall be worn. See Figure C.
8. Avoid contact with coolant, especially guarding the eyes.
9. Non-slip footwear and safety shoes are recommended. See Figure D.
10. Wear ear protectors (plugs or muffs) during extended periods of operation. See Figure E.

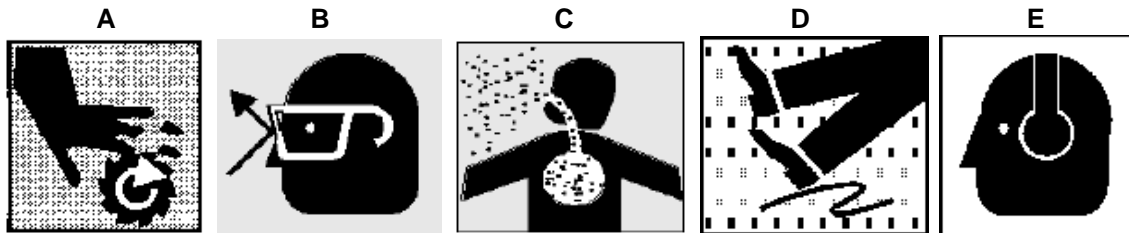

Introduction

This manual is provided by JET covering the safe operation and maintenance procedures for a JET 20-inch Variable Speed Drill Press. This manual contains instructions on installation, safety precautions, general operating procedures, maintenance instructions and parts breakdown. This machine has been designed and constructed to provide years of trouble free operation if used in accordance with instructions set forth in this manual. If there are any questions or comments, please contact either your local supplier or JET. JET can also be reached at our web site: www.jettools.com.

General Specifications

The JET 20-inch Variable Speed Drill presses Models J-2221VS, J-2223VS, J-2232AC and J-2234AC are available in manual speed control or inverter speed control configuration. Electrical power options are single-phase, 115 and 220 volts; or 3-phase, 440 volts.

	<u>Manual Speed Control Models</u>		<u>Inverter Speed Control Models</u>	
Model	J-2221VS	J-2223VS	J-2232AC	J-2234AC
Stock Number	354221	354223	354214	354216
Drilling Capacity:				
Cast Iron (in.)	1-1/4	1-1/4	1-1/2	1-1/2
Steel (in.)	1	1	1-3/8	1-3/8
Spindle to Table Max. (in.)	30-1/4	30-1/4	30-1/4	30-1/4
Spindle to Base Max. (in.)	44-1/2	44-1/2	44-1/2	44-1/2
Spindle to Column Max. (in.)	10-7/16	10-7/16	10-7/16	10-7/16
Motor:				
Rating	2HP, 1-Phase	2HP, 3-Phase	2HP, 3-Phase	2HP, 3-Phase
Voltage	115/220V	220/440V	220V	440V
Pre-wired Voltage	115V	220V	220V	440V
T-Slots (Table/Base):				
Number	2	2	2	2
Size (in.)	5/8	5/8	5/8	5/8
Column Diameter (in.)	4-1/2	4-1/2	4-1/2	4-1/2
Spindle:				
Travel (in.)	6	6	6	6
Taper	MT-3	MT-3	MT-3	MT-3
RPM (variable)	300-2000	300-2000	65-2000	65-2000
Quill:				
Diameter (in.)	3	3	3	3
Travel (in.)	6	6	6	6
Table:				
Overall Size (in.)	22 x 18-3/4	22 x 18-3/4	22 x 18-3/4	22 x 18-3/4
Working Surface (in.)	18-1/8 x 14-3/4	18-1/8 x 14-3/4	18-1/8 x 14-3/4	18-1/8 x 14-3/4
Travel (in.)	18	18	18	18
Base:				
Overall Size (in.)	26 x 19	26 x 19	26 x 19	26 x 19
Working Surface (in.)	15-1/4 x 12-1/16	15-1/4 x 12-1/16	15-1/4 x 12-1/16	15-1/4 x 12-1/16
Overall Dimensions:				
Length (in.)	34-1/4	34-1/4	36-5/8	36-5/8
Width (in.)	27	27	27	27
Height (in.)	78	78	78	78
Net Weight	715 lbs.(325 kgs.)	715 lbs.(325 kgs.)	792 lbs.(325 kgs.)	792 lbs.(325 kgs.)

The above specifications were current at the time this manual was published, but because of our policy of continuous improvement, JET reserves the right to change specifications at any time and without prior notice, without incurring obligations.

Hole centers in Base (all models)

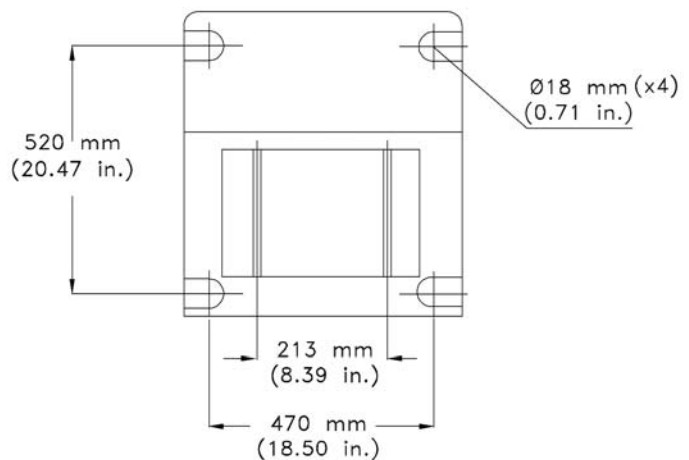

The JET Model J-2221VS and J-2223VS drill presses feature manual speed control. Models J-2232AC and J-2234AC have inverter speed control. This manual contains procedures for both speed control versions. The manual provides separate instructions when differences in operation and maintenance exist.

Refer to Figures 1 and 2 for key features of the drill press.

Operation and Set-Up

Securing the Base

The base of the drill press has four mounting slots; two slots on both sides of the base. The drill press should be level and rest solidly on the floor. Place shims under the four mounting slots in the base as needed to level the drill press.

When securing the base to the floor, apply even torque to the fasteners to prevent distortion of the base.

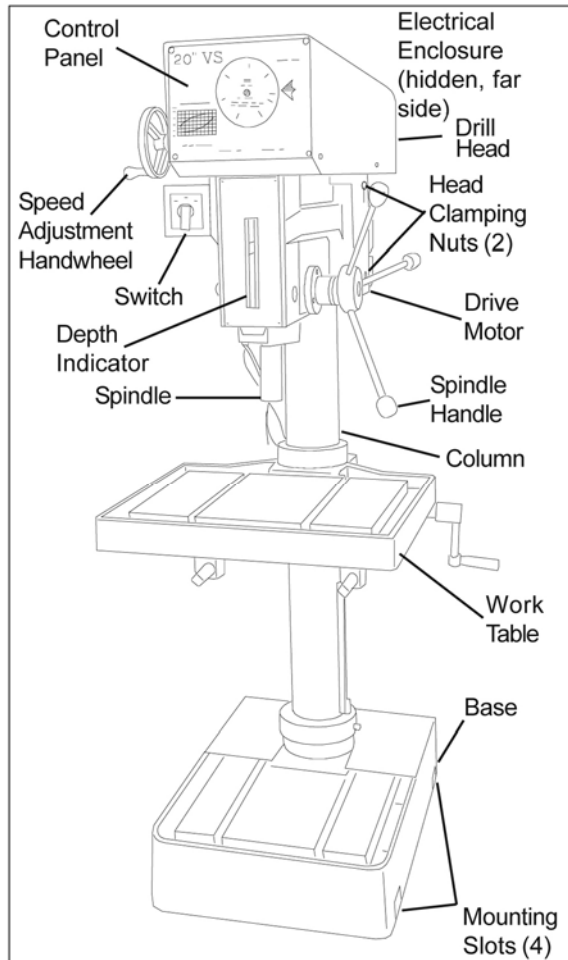

*Figure 1
Drill Press Features
(Manual Speed Control Model)*

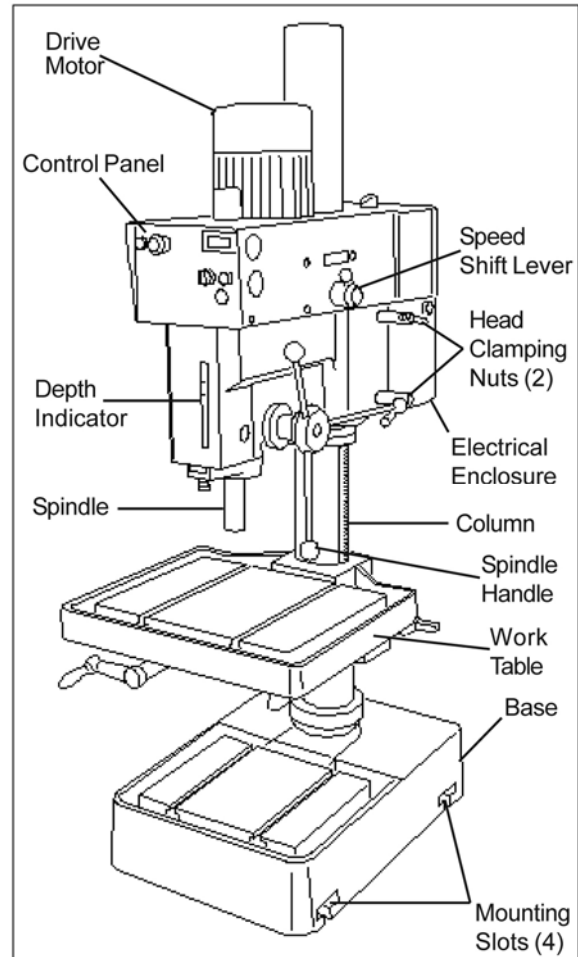

*Figure 2
Drill Press Features
(Inverter Speed Control Model)*

Raising the Drill Head and Table

The drill press is shipped with the table and drill head supported by wooden blocks near the bottom of the column.

The head is raised to the operating position using a strap and hoist, then secured to the column by tightening the hex cap screw. The table is raised to the desired position using the crank handle. See *Adjustments* section for more information.

Electrical Connection

⚠WARNING Electrical connections must be made by a qualified electrician in compliance with all relevant codes. This machine must be properly grounded to help prevent electrical shock and possible fatal injury.

Refer to the *Wiring Diagram* section for wiring information.

The Drill Press is not supplied with a power cord. To connect power, you may either install a power cord with a UL/CSA listed plug, or hard wire the machine directly to a service panel.

If the drill press is to be hard-wired to a panel, make sure a disconnect is available for the operator. (During hard-wiring of the machine, make sure the fuses have been removed or the breakers have been tripped in the circuit to which the drill press will be connected.)

Manual control models: Model J-2221VS (1-Phase) is pre-wired for 110 volts. Model J-2223VS (3-Phase) is pre-wired for 220 volts.

NOTE: If rewiring the J-2221VS or J-2223VS for alternate voltage, you must reconnect the wire on the LED display accordingly (Figure 3), in addition to changing the motor leads.

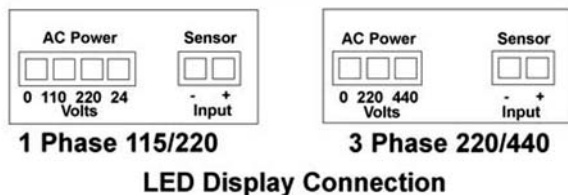

Figure 3

Inverter control models: Model J-2232AC (3-Phase) is pre-wired for 220 volt only. The machine can also be run on 1-Phase power by hooking up the ground, L1 and L2 wires, as explained below.

Model J-2234AC (3-Phase) is pre-wired for 440 volt only.

To wire the drill press with inverter control:

If using a power cord, strip back the cord until about 3 to 4 inches of the lead wires are exposed.

Slide a grommet onto the cord to be installed later in the control box hole, to prevent stress to the power cord.

1. Bring the lead wires through the hole in the side of the control box and connect as follows (refer to Figure 3a):
2. If your incoming power is **single phase**, connect the two leads to L1 and L2, and the green ground wire to the grounding screw.

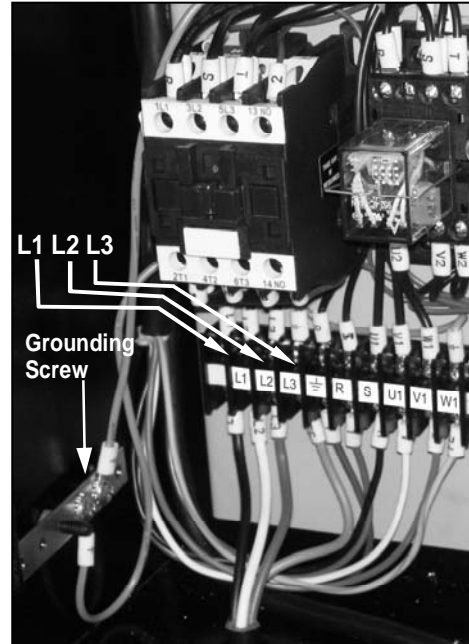

Figure 3a

3. If your incoming power is **three phase**, connect the three leads to L1, L2 and L3, and the green ground wire to the grounding screw.

This drill press must be properly grounded. Make sure the green ground wire is secured to the grounding screw as described.

Make sure the power available matches the power requirement of the drill. When the drill is connected properly, the spindle turns clockwise in a conventional drilling rotation. If the spindle does not turn clockwise, disconnect the drill from the power supply and reverse two of the three power leads (except ground wire *green*).

Operating Controls

Manual Speed Control (Models J-2221VS and J-2223VS)

Refer to Figure 4.

Spindle Selector Switch

A three-position selector switch is provided at the left side of the drill head. It is used to select spindle rotation: reverse (REV), off (OFF), and forward (FWD).

Speed Control Hand Wheel

CAUTION To avoid damage to the speed adjustment mechanism, the drive motor must be operating before attempting to adjust the speed setting.

A speed control hand wheel is provided on the left front of the head (Figure 4). The handle is turned clockwise to increase spindle speed and counterclockwise to reduce speed. To set the speed, the speed control handle is turned until the pointer on the front panel is at the desired speed.

Speed Indicator

An LED spindle speed indicator is provided on the front panel. The LED indicates speeds from 300 to 2000 rpm.

A selector switch is provided at the left side of the drill head. The two-position switch is used to start and stop the drive motor.

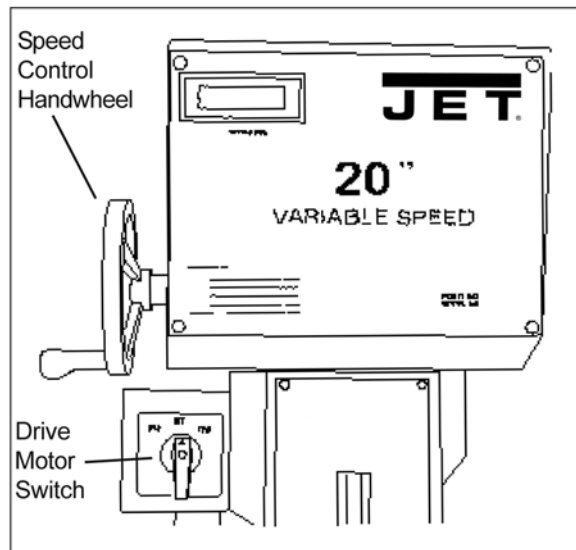

Figure 4
Control Panel (Manual Speed Control)

Inverter Speed Control (Models J-2232AC and J-2234AC)

Speed Shift Lever

CAUTION To avoid damage to the speed adjustment mechanism, the drive motor must be operating before attempting to adjust the speed setting.

A speed shift lever is on the right side of the head (refer to Figure 2 for location). The handle is turned clockwise to increase spindle speed and counterclockwise to reduce speed.

Front Panel

The front panel (Figure 5) is mounted on the front of the drill head. The panel contains all the controls required to operate the drill press. There are additional controls on the inverter mounted on the left side of the drill head. The inverter is pre-programmed at the factory and the settings are not to be changed!

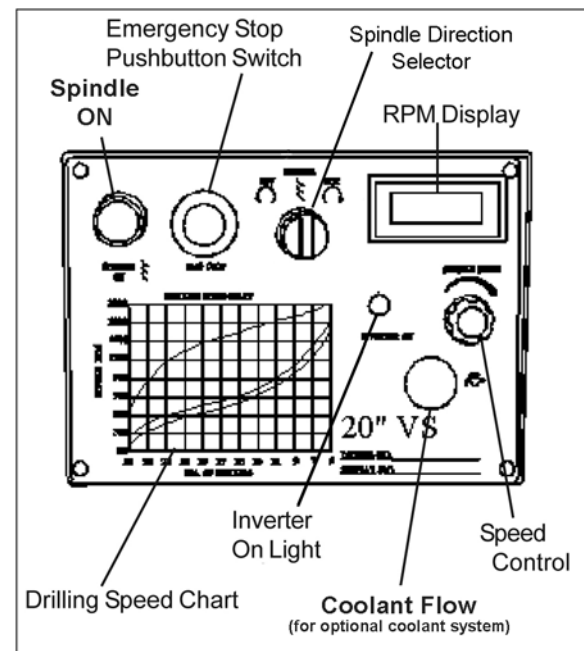

Figure 5
Control Panel (Inverter Control)

Inverter On Indicator

The INVERTER ON light indicates that the inverter is powered up.

Spindle On Pushbutton Switch

The SPINDLE ON pushbutton is used to start the drive motor. To stop the motor, the pushbutton is pressed (the switch toggles on and off).

Emergency Stop Pushbutton Switch

The mushroom shaped EMG. STOP pushbutton switch provides a quick means of stopping the drive motor. To reset the pushbutton switch, the knob is turned clockwise (as shown on the face of the knob).

RPM Display

The spindle speed display shows the spindle RPM selected by the speed control knob.

Spindle Speed Knob

The SPINDLE SPEED knob is used to set the desired spindle speed (clockwise increases).

Spindle Selector

The SPINDLE selector switch is used to set the desired direction of spindle rotation. The REV. (reverse) setting will provide counterclockwise rotation. The FOR. setting will provide clockwise rotation.

Drilling Speed Chart

A DRILLING SPEED CHART is provided on the front panel. The chart can be used to select the speed required for various drill sizes (0.196 inch to 1.000 inch — 5 mm to 25 mm) and materials (steel, cast iron, aluminum, and copper). The chart defines spindle speeds from 300 to 2000 RPM.

Depth Indicator — All Models

Refer to Figure 6.

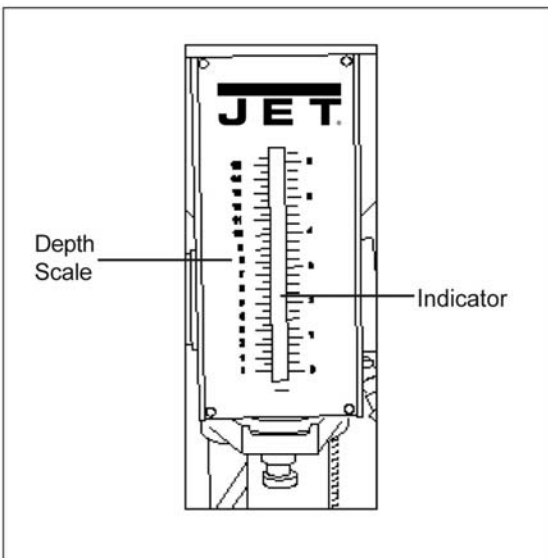

Figure 6

A drilling depth indicator is provided on the front of the drill head. The indicator can be set for depths up to 6.5 inches (16.5 mm). A knurled knob is provided at the front, underside of the head. Before starting the motor, set the end of the drill against the surface into which the hole is to be drilled. The indicator is zeroed out using the knurled knob. The motor is started and the hole drilled until the indicator pointer reaches the desired depth.

Maintenance

Replacement of Drive Belt

⚠WARNING Make sure to disconnect electrical power to the drill press to avoid the possibility of inadvertent operation and exposure to potentially lethal voltage levels.

Manual Speed Control (Models J-2221VS and J-2223VS)

1. Start drill press. Set speed control to highest speed. Stop drill press.
2. Disconnect electrical power by setting drill press circuit breaker to OFF.
3. Remove head cover.
4. Remove belt. (With speed control setting at the highest speed, the belt should be loose enough to remove.)
5. Install the replacement belt. Install the head cover.
6. Set the drill press circuit breaker ON.
7. Operate the drill press to verify correct operation.

Inverter Speed Control (Models J-2232AC and J-2234AC)

1. Disconnect electrical power by setting drill press circuit breaker to OFF.
2. Remove pan screws from small cover (around column). Remove pan screws and eight bolts from head cover.
3. Loosen set screw and remove shift lever.
4. Remove plastic spindle cup.
5. Remove head cover. Leave small cover in place.
6. Disconnect electrical wiring from motor junction box. Remove motor from mounting plate.
7. Remove motor mounting plate.
8. Remove three screws from pulley covers (discs). Remove used belt. Install the replacement belt.
9. Install pulley covers and secure with three screws in each pulley cover.
10. Install motor mounting plate. Install motor and connect electrical wiring (refer to *Wiring Diagram* section for wiring details).
11. Install the head cover and secure with pan screws and eight bolts.

12. Secure small head cover to head cover using pan screws.
13. Set the drill press circuit breaker ON.
14. Operate the drill press to verify correct operation.

Replacement of Motor

⚠WARNING Make sure to disconnect electrical power to the drill press to avoid the possibility of inadvertent operation and exposure to potentially lethal voltage levels.

Manual Speed Control (Models J-2221VS and J-2223VS)

1. Remove drive belt (refer to *Replacement Of Drive Belt*).
2. Disconnect electrical wiring from motor junction box.
3. Remove nuts from mounting studs securing motor to drill head. Remove motor.
4. Remove upper and lower pulleys and related components from motor shaft.
5. Install upper and lower pulleys and related components on replacement motor shaft.
6. Install motor on mounting studs and secure with nuts.
7. Connect electrical wiring (refer to *Wiring Diagram* section for wiring details).
8. Install drive belt (refer to *Replacement Of Drive Belt*).
9. Operate drill press to verify proper operation.

Inverter Speed Control (Models J-2232AC and J-2234AC)

Refer to *Replacement Of Drive Belt* for instructions on removal of the drive motor.

Lubrication

Following are lubrication recommendations for drill press components.

Manual Speed Control (Models J-2221VS and J-2223VS)

1. Spindle pulley drive: Lubricate spindle splines occasionally with light grease.
2. Quill and column: Lubricate with light film of oil.
3. Lift rack: Lubricate regularly with SAE 20 oil (clean rack with kerosene before applying oil).
4. Variable drive:
 - a. Speed control fork: service oil hole with SAE 20 oil once a week.

- b. Countershaft spindle and push rod: Lubricate with SAE 20 oil occasionally.
- c. Speed control handle cam: Clean and grease with medium cup grease annually.

Inverter Speed Control (Models J-2232AC and J-2234AC)

1. Spindle pulley drive: Lubricate spindle splines occasionally with light grease.
2. Quill and column: Lubricate with light film of oil.
3. Lift rack: Lubricate regularly with SAE 20 oil (clean rack with kerosene before applying oil).
4. Variable speed drive:
 - a. Periodically check oil level in sight gauge on (left side of head) (refer to *Figure 7*).
 - b. If level is below centerline of sight gauge, add oil.
 - c. To add oil, remove oil fill tube cover plate. Pull fill tube out of hole in head cover.
 - d. Add SAE 20 oil to bring oil level up to the centerline of the sight gauge.
 - e. Put end of fill tube back through hole in head cover. Install fill tube cover and secure with two screws.

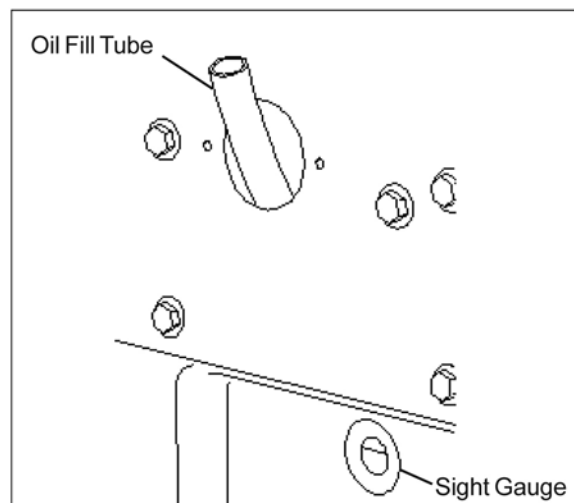

Figure 7

Adjustments

Table Adjustment

Refer to Figure 8.

The table can be raised or lowered to accommodate the height of the workpiece. To raise or lower the table, loosen the table lock using the hand crank. Then use the hand crank to move the table to the desired height. Then lock the table in position.

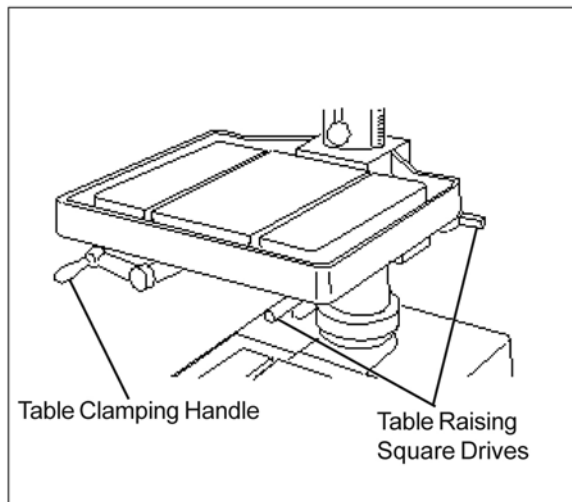

Figure 8

Radial Head Adjustment (All Models)

⚠ WARNING Change the radial position of the drill head only if the drill press base is secured to the floor. Swinging the drill head without the base being secured to the floor will cause the drill press to become unstable and tip over resulting in injury and/or damage to the machine.

The radial position of the drill head can be changed to accommodate the drilling of a hole that may be offset from the center of the table. Reposition the drill head as follows:

1. Loosen the two clamping hex nuts using the hex socket wrench provided with the machine.
2. The swing the drill head to the desired position.
3. Tighten the two clamping nuts.

Speed Pickup Adjustment (All Models)

1. Loosen screws securing speed pickup (ref. 68A, page 23) to plate (ref. 69A, page 23).
2. Adjust the speed pickup gap to approximately 1/8-inch. Re-tighten screws.

3. Operate drill press to verify that speed readout is operating correctly.

Operating Precautions

The following operating and safety precautions must be observed in order to avoid harm to the operator or damage to the drill press.

1. The head assembly must be locked to the column so the thrust produced by drilling will not force the head assembly up the column.
2. The work table must be locked to the column so it will not be forced down the column.
3. Before drilling, release the quill lock nut to permit free travel of the quill.
4. Be sure the belt is tightened to the proper tension.
5. **DO NOT** start to drill the workpiece until making certain the workpiece is held down securely.
6. **MAKE SURE THE DRIVE MOTOR IS RUNNING BEFORE** turning the speed control handwheel in either direction.
7. Point of operation protection is required for maximum safety. This remains the responsibility of the user/purchaser since conditions differ between jobs.
8. Make sure the drill is secured in the spindle or chuck before attempting to use the drill press.
9. Make sure the spindle taper is clean and free of burrs, scoring, and galling to assure maximum gripping.
10. Lock the quill in position when using any side-loaded tool.

Drilling Recommendations

Speeds for Drilling

The speed of a drill is usually measured in terms of the rate at which the outer periphery of the tool moves in relation to the work being drilled. The common term for this is Surface Feet per Minute (SFM). The relationship of SFM is expressed in the following formulas:

$$\text{SFM} = 0.26 \times \text{rpm} \times \text{Drill Diameter (in inches)}$$

$$\text{RPM} = 3.8 \times \frac{\text{SFM}}{\text{Drill diameter (in inches)}}$$

In general, the higher the speed the shorter the drill life. Operating at the low end of the speed range for a particular material will result in longer life. The most efficient speed for operating a drill depends on many variables:

1. Composition and hardness of material.
2. Depth of the hole.
3. Efficiency of the cutting fluid.
4. Type and condition of the drilling machine.
5. Desired quality of the hole.
6. Difficulty of set-up.

Feeds for Drilling

The feed of a drill is governed by the size of the tool and the material drilled. Because the feed rate partially determines the rate of production and also is a factor in tool life, it should be chosen carefully for each job. In general, the most effective feeds will be found in the following ranges:

<u>Diameter of Drill (inches)</u>	<u>Feed per Revolution (inches)</u>
Under 1/8	0.001 to 0.002
1/8 to 1/4.....	0.002 to 0.004
1/4 to 1/2.....	0.004 to 0.007
1/2 to 5/8.....	0.007 to 0.015

Indication of Extreme Speeds and Feeds

A drill that splits up the web is evidence of too much feed or insufficient tip clearance at the center as a result of improper grinding. The rapid wearing away of the extreme outer corners of the cutting edges indicates that the speed is too high. A drill chipping or braking out at the cutting edges indicates that either the feed is too heavy or the drill has been ground with too much tip clearance.

Speeds for High Speed Steel Drills

<u>Material</u>	<u>Speed In SFPM</u>
Alloy Steel — 300 to 400 Brinell	20 - 30
Stainless Steel	30 - 40
Automotive Steel Forgings	40 - 50
Tool Steel, 1.2C	50 - 60
Steel, .4C to .5C.....	70 - 80
Mild Machinery Steel, .2C to .3C	80 - 110
Hard Chilled Cast Iron.....	30 - 40
Medium Hard Cast Iron	70 - 100
Soft Cast Iron.....	100 - 150
Malleable Iron	80 - 90
High Nickel Steel or Monel	40 - 50
High Tensile Bronze.....	70 -150
Ordinary Brass and Bronze	200 - 300
Aluminum and its Alloys	200 - 300
Magnesium and its Alloys.....	250 - 400
Slate, Marble, and Stone.....	15 -25
Plastics and similar material (Bakelite) ..	100 - 150
Wood.....	300 -400
Titanium Alloys.....	10 - 25
Titanium Alloy Sheet	50 - 60

In cases where carbon steel drills are applicable, the drill should be run at speeds of from 40 to 50 percent of those given above.

Optional Equipment

Coolant System Installation

1. Remove the large reservoir cover plate from the machine base. Tap 1/4-20 threads in the 4 pilot holes.
2. Install the cover plate back onto the machine base.
3. Insert the pump into the opening, utilize the screws from the small round cover plate to fasten the pump to the base.
4. Position the power switch and valve bracket on the spindle casting. Mark mounting hole locations and drill holes. (Refer to Figure 8)

Note: Mount components near the lower edge of the spindle casting. Do not mount components above the line shown in Figure 9.

5. Install the power switch and valve bracket with the provided fastener hardware.

6. Install the 3/8-inch hose coupling to the coolant pump. If needed, apply a light coat of pipe sealant or thread seal tape to the threads to prevent leakage.
7. Mount the flow valve to the bracket, connect the supply hose to the pump and valve, use hose clamps at the ends.
8. Install the flexible nozzle to the flow valve.
9. Install the 1/2-inch hose coupler to the worktable, and seal threads if needed. Connect the return hose.
10. Connect the power cord to a suitable source and ground (refer to *General Electrical Cautions*).
11. Fill the reservoir with appropriate machining coolant.



Figure 8 Suggested installation

Do not mount components above this line.

Power switch - mounting plate flush with bottom edge of spindle casting.

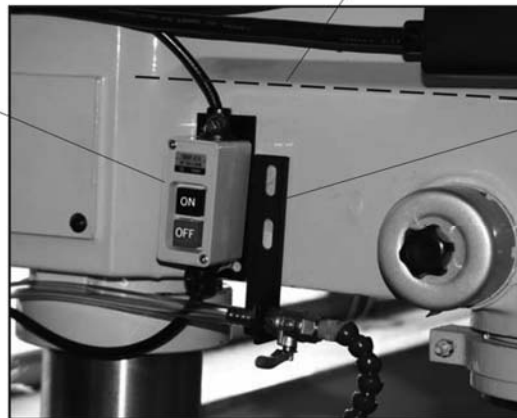

Flow valve mounting bracket.

Figure 9: Installation Detail

Troubleshooting

Trouble	Probable Cause	Remedy
Spindle does not turn.	Motor overload protector tripped.	Press motor overload reset button.
	Circuit breaker tripped.	Reset circuit breaker.
	Branch circuit breaker tripped or fuse blown.	Reset branch circuit breaker/replace fuse.
	Open wire in switch circuit.	Repair open circuit.
	Defective switch.	Replace switch.
	Broken drive belt.	Replace drive belt.
Spindle noisy.	Damaged spindle bearings.	Replace bearings.
	Worn spline.	Replace spline.
Drill stalls.	Worn drive belt.	Check condition of belt. Replace if glazed or slipping on pulleys.
	Excessive feed rate for size of drill and material being drilled. No cutting fluid or improper cutting fluid.	Reduce feed pressure or use cutting fluid. Use correct cutting fluid.
Poorly drilled holes.	Drill dull.	Sharpen drill.
	Lack of rigidity in hold-down method.	Check that all T-slot hold-downs are tight and that table-lock and drill head bolts are tight.
	Speed too fast for material and drill size.	Check spindle speed recommendations. Reduce speed if necessary.
	Feed too fast for material and drill size.	Reduce feed rate.
	No or improper cutting fluid or coolant being used.	Use cutting fluid, or change to proper fluid or coolant for material being drilled.
Motor overheating.	Improperly ground drill bit.	Check for proper angles and reliefs. Regrind to proper geometry.
	Electrical circuit fault.	Check current draw in circuit. Make sure current draw is the same as rating on motor plate.
	Oversize drill.	Reduce drill size.
	Excessive feed.	Reduce feed rate.
Table cannot be raised.	No cutting fluid, or wrong fluid.	Use correct cutting fluid for the material and drill.
	Lack of lubrication.	Lubricate.
No speed readout.	Speed pickup out of adjustment or failed.	Adjust gap between speed pickup and post spindle pulley. If there is no readout on the LED speed indicator after adjusting the gap, replace the speed pickup.

Replacement Parts

Replacement parts are listed on the following pages. To order parts or reach our service department, call 1-800-274-6848, Monday through Friday (see our website for business hours, www.jettools.com). Having the Model Number and Serial Number of your machine available when you call will allow us to serve you quickly and accurately.

Exploded View – Drill Head – Manual Speed Control (J-2221VS and J-2223VS)

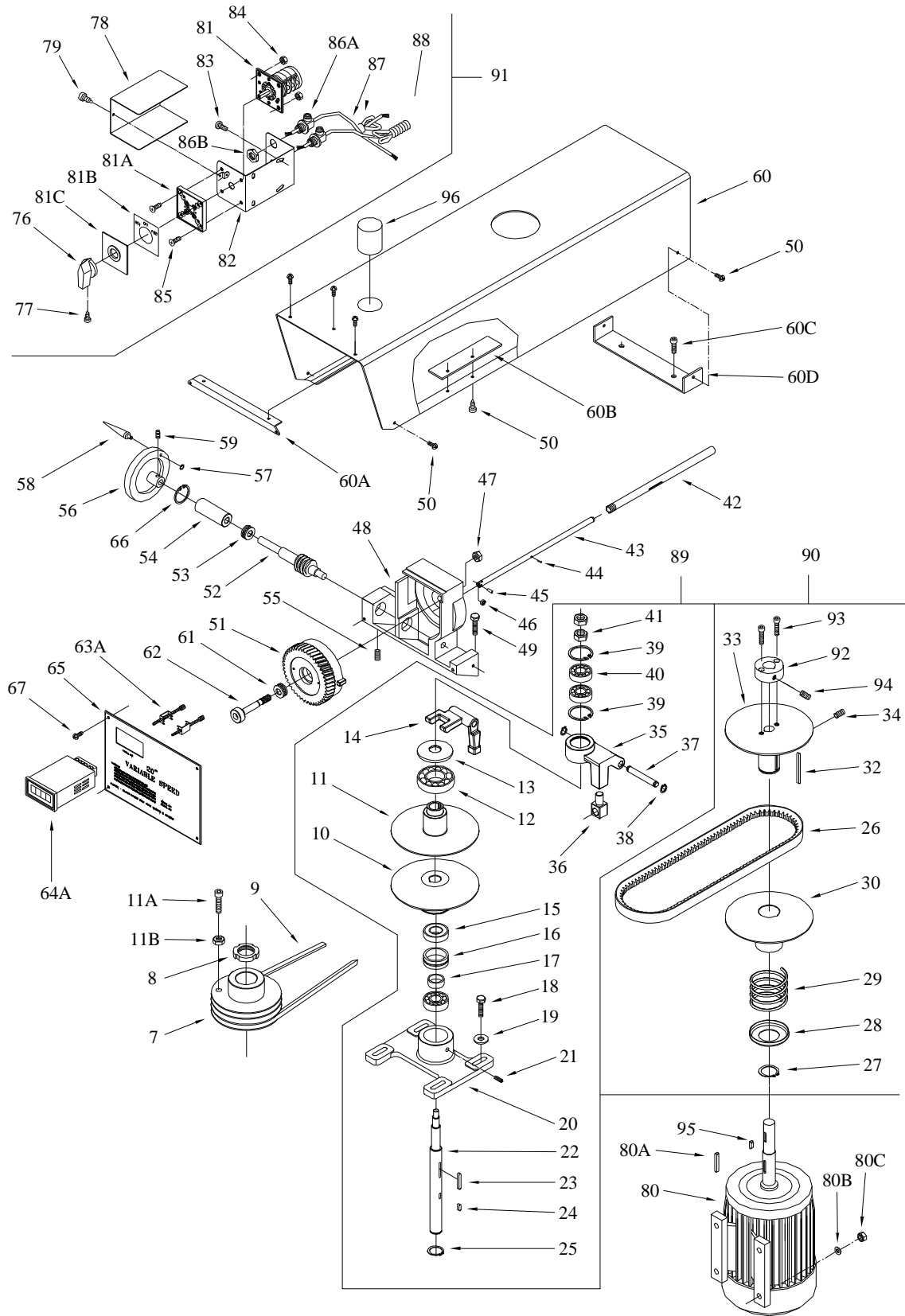

Parts List – Drill Head – Manual Speed Control (J-2221VS and J-2223VS)

Index No.	Part No.	Description	Size	Qty
7	5510077	Spindle Step Pulley		1
8	5510078	Spindle Nut		1
9	5510079	V-Belt		1
10	5510080	VS Lower Spindle Pulley		1
11	5510081	VS Upper Spindle Pulley		1
11A	5513673	Cap Screw		1
11B	5513674	Hex Nut		4
12	5510082	Ball Bearing		1
13	5510083	Bearing Cover		1
14	5510084	Speed Change Lever		1
15	5510085	Ball Bearing		2
16	5510086	Bushing		1
17	5510087	Bushing		1
18	5510088	Hex Bolt		4
19	5510089	Washer		4
20	5510090	Bearing Housing		1
21	5510091	Set Screw		1
22	5510092	Spindle Mid Shaft		1
23	5510093	Key		1
24	5510094	Key		1
25	5510095	C-Ring (Shaft)		1
26	5510096	Variable Speed Belt		1
27	5510097	C-Ring (Shaft)		2
28	5510098	Spring Cover		1
29	5510099	Spring		1
30	5510100	VS Lower Motor Pulley		1
32	5510102	Key		1
33	5510103	VS Upper Motor Pulley		1
34	5510104	Set Screw		1
35	5510105	Speed Change Bracket		1
36	5510106	Link		1
37	5510107	Shaft		1
38	5510108	C-Ring (Shaft)		1
39	5510109	C-Ring (Hole)		1
40	5510110	Ball Bearing		2
41	5510111	Nut		2
42	5512114	Control Rod Sleeve		1
43	5512115	Control Rod		1
44	5510114	Pin Spring		1
45	5510115	Pin		1
46	5510116	Roller		1
47	5510117	Hex Nut		1
48	5512116	Housing		1
49	5513675	Cap Screw	M8x35	2
50	5513676	Pan Head Screw		6
51	5510121	Helix Gear		1
52	5510122	Worm Gear		1
53	5510123	Thrust Bearing		1
54	5510124	Bushing		1
55	5513677	Set Screw		1
56	5510126	Hand Wheel (includes #58)		1
57	5510127	Retaining Ring		1
58	5510126	Hand Grip		1
59	5510129	Set Screw		1
60	J-5513678	Pulley Cover Assembly (incl 60A,60B,60C,60D)		1
60A	J-5513679	Nameplate Bracket		1
60B	J-5513680	Cover Plate		1
60C	5513681	Cap Screw		2
60D	J-5513682	Plate Bracket		1

Index No.	Part No.	Description	Size	Qty
61	5510131	Thrust Bearing		1
62	5510132	Shaft		1
63A	5513683	Cap Screw		2
64A	5513519	LED Display	115/230/24V	1
	5513736	LED Display	220/440	1
65	5513690	Face Plate		1
66	5513685	C-Ring (Hole)		1
67	5510137	Round Head Screw		4
76	5511848	Knob		1
77	5514634	Set Screw	M3x8	1
78	5511849	Cover		1
79	5513354	Screw		2
80	J-5510344	Motor	2HP 1PH 115/220V	1
	5510345	Motor	2HP 3PH 220/440V	1
80A	5517320	Square Key		1
80B	5517321	Flat Washer		4
80C	5517322	Hex Nut		4
81	5517323	Fwd/Rev Switch	1 Phase	1
	5517331	Fwd/Rev Switch	3 Phase	1
81A	5517324	Switch Plate		1
81B	5517325	Label		1
81C	5517326	Label Cover		1
82	5513356	Switch Box		1
83	5513357	Screw		2
84	5513358	Hex Nut		4
85	5513359	Screw		4
86A	5517327	Strain Relief		2
86B	5517328	Hex Nut		2
87	5517329	Connection Cord		1
88	5517330	Power Cord		1
89	5513935	VS Spindle Pulley Assembly		1
90	5513934	VS Motor Pulley Assembly		1
91	5513355	Switch Assembly (includes items 76-79,81-85)	1 Phase	1
	5514716	Switch Assembly (includes items 76-79,81-85)	3 Phase	1
92	2221VS-92	Bushing		1
93	TS-1503041	Socket Head Cap Screw	M6 x 16	2
94	TS-1524021	Set Screw	M8 x 10	1
95	2221VS-95	Key	5 x 20 mm	1
96	5515285	Spindle Cap		1

Exploded View – Drill Head – Inverter Speed Control (J-2232AC and J-2234AC)

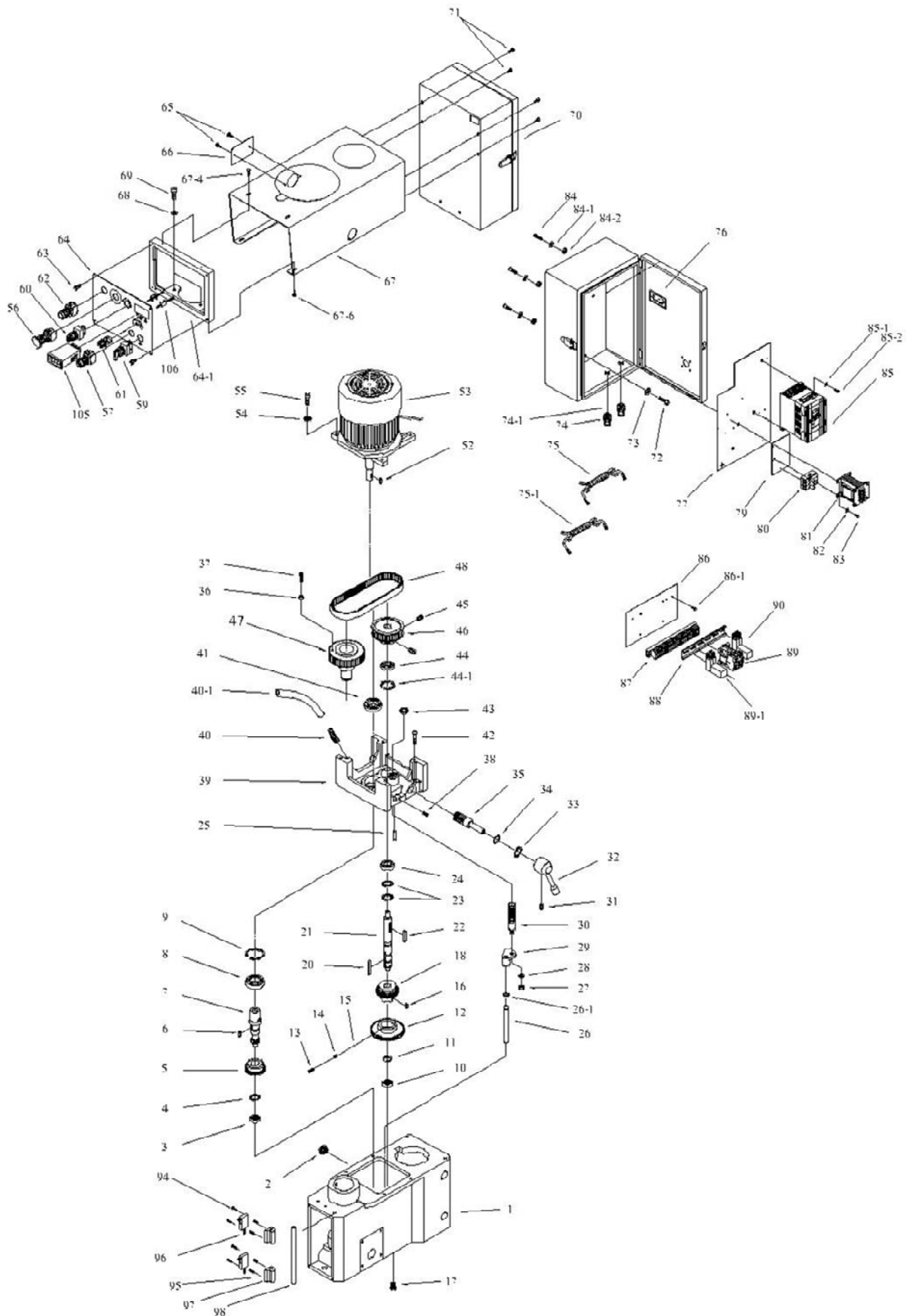

Parts List – Drill Head – Inverter Speed Control (J-2232AC and J-2234AC)

Index No.	Part No.	Description	Size	Qty
1	J-5517332	Head Casting		1
2	5510142	Oil Window		1
3	5510143	Ball Bearing		1
4	5510144	Retaining Ring		1
5	5510145	Gear	32T	1
6	5510146	Key		1
7	5510147	Drive Shaft	13T	1
8	5510148	Ball Bearing		1
9	5510149	Retaining Ring		1
10	5510150	Ball Bearing		1
11	5510151	Retaining Ring		1
12	5510153	Gear	55T	1
13	5510152	Set Screw		1
14	5510155	Spring		1
15	5510154	Steel Ball		1
16	5510159	Key		1
17	5517333	Drain Plug	3/8 NPT	1
18	5510158	Gear	18T	1
20	5510160	Key		1
21	5510161	Mid Shaft		1
22	5510162	Key		1
23	5510163	Retaining Ring		2
24	5510164	Ball Bearing		1
25	5510165	Pin		1
26	5510166	Bar		1
26-1	5517334	Ring		1
27	5510167	Hex Nut		1
28	5510168	Spring Washer		1
29	5510169	Speed Change Block		1
30	5510170	Gear Bar		1
31	5510171	Set Screw		1
32	5517335	Speed Lever		1
33	5517336	Retaining Ring		1
34	5510173	Oil Seal		1
35	5510177	Gear Shaft	18T	1
36	5517337	Hex Nut		1
37	5517338	Cap Screw		1
38	5510178	Set Screw		1
39	5517339	Gearbox Top Cover		1
40	5510180	Oil Fill Fitting		1
40-1	5517340	Fill Tube		1
41	5510181	Oil Seal		1
42	5510182	Bolt		1
43	5510183	Oil Seal		1
44	5510184	Oil Seal		1
44-1	5517341	Retaining Ring		1
45	5510185	Set Screw		1
46	5510186	Drive Pulley		1
47	5517342N	Spindle Pulley with Driving Sleeve	48T	1
48	5517343	Belt	720x8	1
52	5510192	Key		1
53	J-5517349	Motor	2HP, 3PH, 220V	1
	J-5517350	Motor	2HP, 3PH, 440V	1
54	5510194	Washer		4
55	5510195	Screw		4
56	5510204	E-stop Switch		1
56-1	5510197	Speed Proximity Switch		1
56-2	5510198	Proximity Switch Bracket		1
57	5510201	Indicator Light		1
59	5510199	Pump Selector Switch		1
60	5510200	Forward/Reverse Switch		1
61	5510196	Speed Control Potentiometer		1

Index No.	Part No.	Description	Size	Qty
62	5510202	Green Pushbutton Switch		1
63	5510206	Screw		4
64	5517351	Control Panel		1
64-1	5517352	Plate Bracket		1
65	5510209	Pan Head Screw		2
66	5510210	Oil Filler Cover		1
67	J-5517353	Pulley Cover		1
67-4	5510215	Pan Head Screw		2
67-6	5517357	Screw		2
68	5510216	Spring Washer		2
69	5510217	Screw		2
70	J-5517359	Enclosure (w/door & latch)		1
71	5510219	Screw		4
72	5510220	Bolt		4
73	5517360	Washer		4
74	5510222	Cable Relief		1
74-1	5517361	Cable Relief		1
75	5510223	Electric Cable		1
75-1	5517362	Electric Cable		1
76	5510224	Window Cover		1
77	5517363	Component Mounting Panel		1
79	5510227	Insulation Board		1
80	5510228	Fuse Block		1
81	5510229	Transformer		1
82	5517364	Washer		4
83	5517365	Pan Head Screw		4
84	5517366	Cap Screw		4
84-1	5517367	Lock Washer		4
84-2	5517368	Hex Nut		4
85	5510233-1/3	Delta Inverter, M-type (<i>serial no. 10110090 and higher</i>)..220V, 1/3PH		1
	5512670	Delta Inverter, M-type	440V, 3PH	1
85-1	5517371	Flat Washer		4
85-2	5517372	Screw		4
86	5517373	Sub-Panel		1
86-1	5517374	Screw		4
87	5510235	Terminal Block		1
88	5517375	Mounting Rail		1
89	5510237	Contact		1
89-1	5510238	Relay		1
90	5510240	Relay		1
94	5510242	Screw		2
95	5510243	Screw		2
96	5510244	Microswitch		2
97	5510245	Microswitch Bracket		2
98	5510246	Microswitch Support Rod		1
99	5514648	Electrical Enclosure Complete	220V, 3PH	1
	5514649	Electrical Enclosure Complete	440V, 3PH	1
105	5513519	LED Display	24V	1
106	5513683	Cap Screw		2
107	5515285	Spindle Cap		1

Exploded View – Spindle Components (All Models)

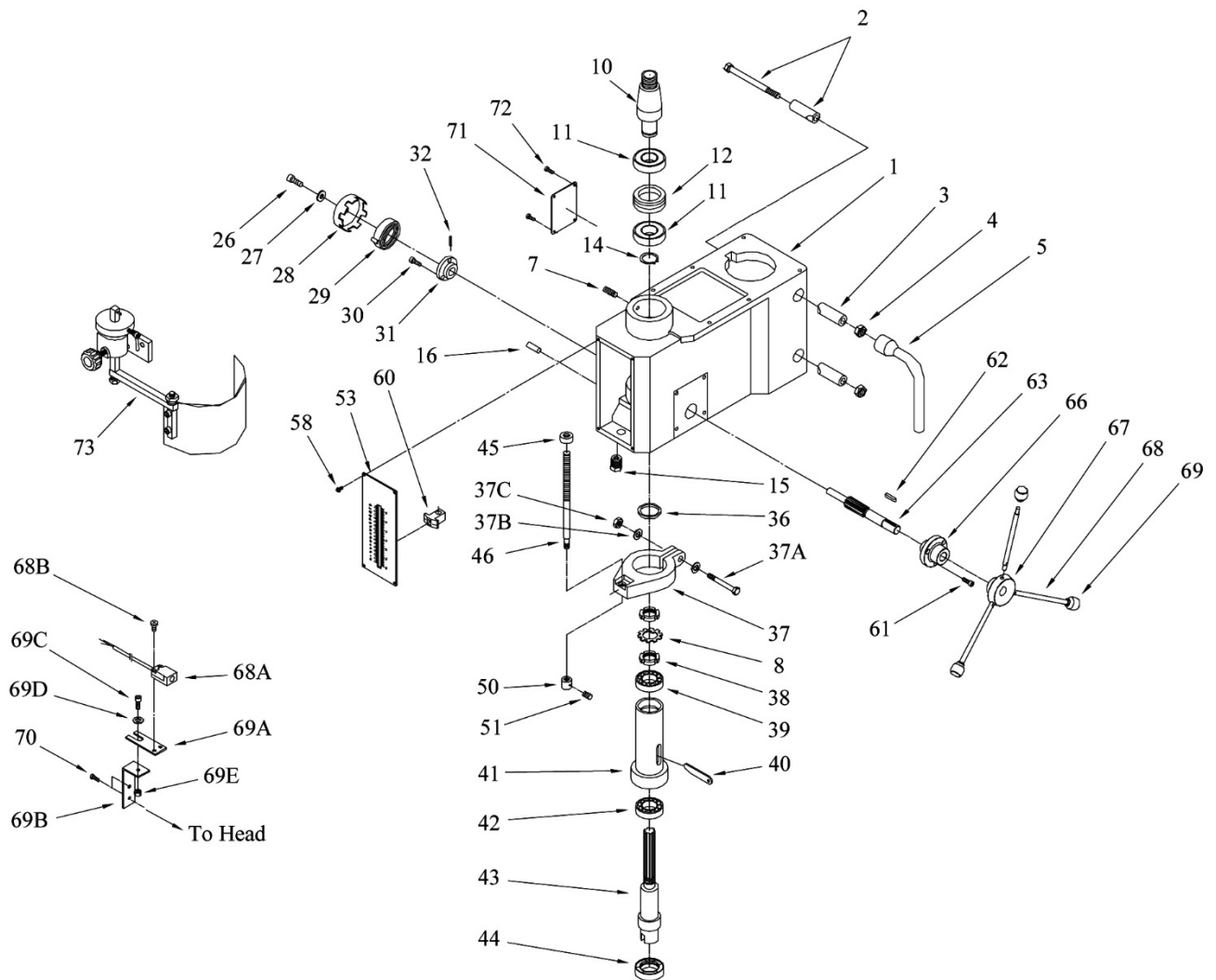

Parts List – Spindle Components (All Models)

Index No.	Part No.	Description	Size	Qty
1	J-5517332	Head Casting		1
2	5517376	Hex Shoulder Bolt		2
3	5517378	Cam Lock Rod		2
4	5510250	Hex Nut		2
5	5510251	Hex Head Wrench		1
7	5510252	Set Screw		1
8	5517379	External Tooth Washer		1
10	5510253	Driving Sleeve (for J-2221VS, J-2223VS only)		1
11	5510254	Ball Bearing		2
12	5510255	Spacer		1
14	5510256	C-Ring		1
15	5510258	Set Screw		1
16	5510259	Roll Pin		1
26	5510261	Socket Head Screw		1
27	5510262	Washer		1
28	5510263	Container (includes #29)		1

Index No.	Part No.	Description	Size	Qty
29	5510263	Return Spring		1
30	5510265	Phillips Head Screw	3/16x3/4 in.	3
31	5510266	Spring Seat		1
32	5510267	Spring Pin		1
36	5513770	Rubber Washer		1
37	J-5513771	Quill Band		1
37A	5517380	Hex Shoulder Bolt		1
37B	5517381	Flat Washer		2
37C	5517382	Hex Nut		1
38	5513772	Lock Nut		2
39	5513773	Ball Bearing		1
40	5513774	Drift Pin		1
41	5510268	Quill		1
42	5510269	Ball Bearing		1
43	5510270	Spindle		1
44	5510271	Oil Seal		1
45	5510272	Nut		1
46	5510273	Depth Rod		1
50	5510276	Retainer		1
51	TS-1523011	Set Screw	M6x6	1
53	5510278	Depth Scale		1
58	5510279	Round Head Cap Screw		4
60	5510280	Key		1
61	5510281	Socket Head Screw		3
62	5510282	Key		1
63	5510283	Feed Shaft		1
66	5510284	Feed Shaft Seat		1
67	J-5510285	Hub		1
68	5510286	Spoke		3
68A	5513515	Magnetic Pickup		1
68B	5513687	Pan Head Screw		2
69	5510287	Knob		3
69A	5517383	Adjustable Plate		1
69B	5517384	Mag. Pickup Bracket		1
69C	5513689	Cap Screw		1
69D	5517385	Flat Washer		1
69E	5517386	Hex Nut		1
70	5517387	Screw		2
71	5511849	Cover		1
72	5513354	Screw		4
73	32106A	Safety Shield Assembly (for 20" DP)		1

Exploded View – Safety Shield Assembly (All Models)

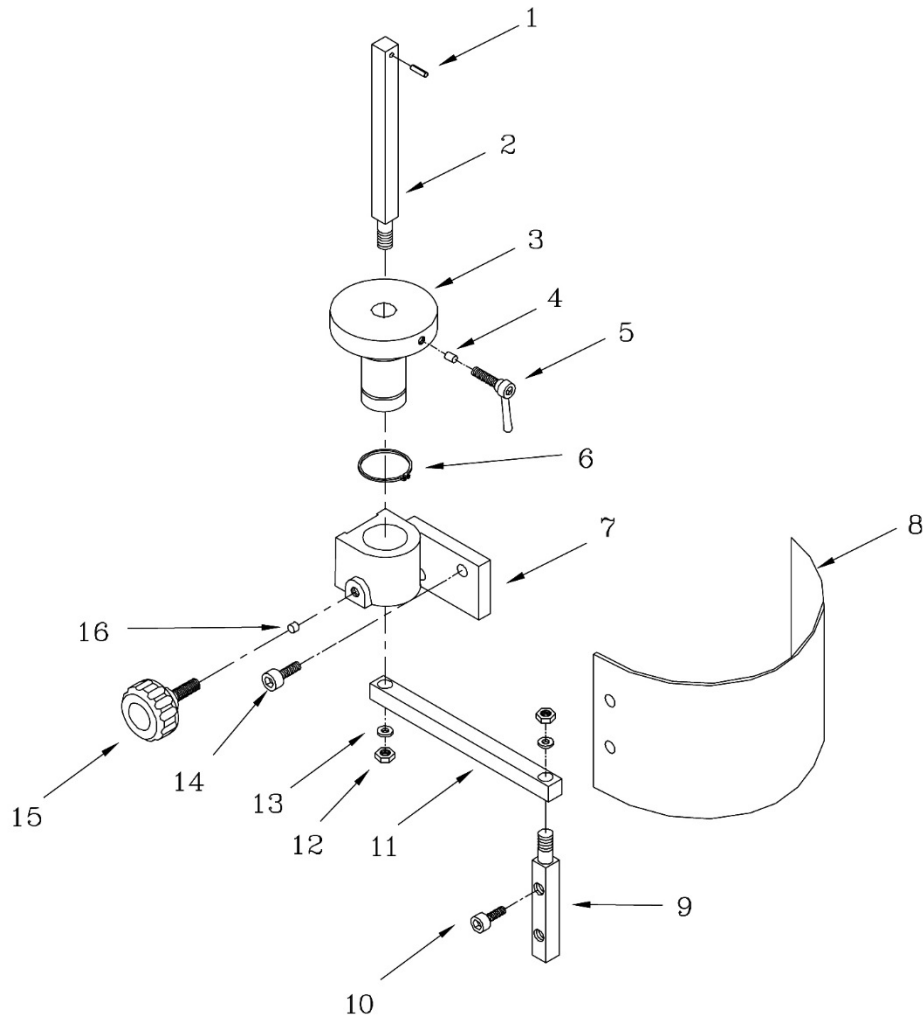

Parts List – Safety Shield Assembly (All Models)

Index No.	Part No.	Description	Size	Qty
1	6293347	Spring Pin	3x16	1
2	32106A-2	Support Bracket Bar		1
3	32106A-3	Bushing		1
4	32106A-4	Spacer		1
5	32106A-5	Lock Handle	M6x20	1
6	32106A-6	C-Clip	S30	1
7	32106A-7	Bracket		1
8	32106A-8	Safety Shield	530x210mm	1
9	32106A-9	Lower Bracket Bar		1
10	TS-1504021	Hex Socket Head Cap Screw	M8x12	1
11	32106A-11	Support Arm		1
12	TS-0640091	Hex Nut	3/8"	1
13	TS-0720091	Spring Washer	3/8"	1
14	TS-1504041	Hex Socket Head Cap Screw	M8x20	1
15	32106A-16	Lock Bolt with Knob	M8	1
16	32106A-17	Spacer		1

Exploded View – Table and Base (All Models)

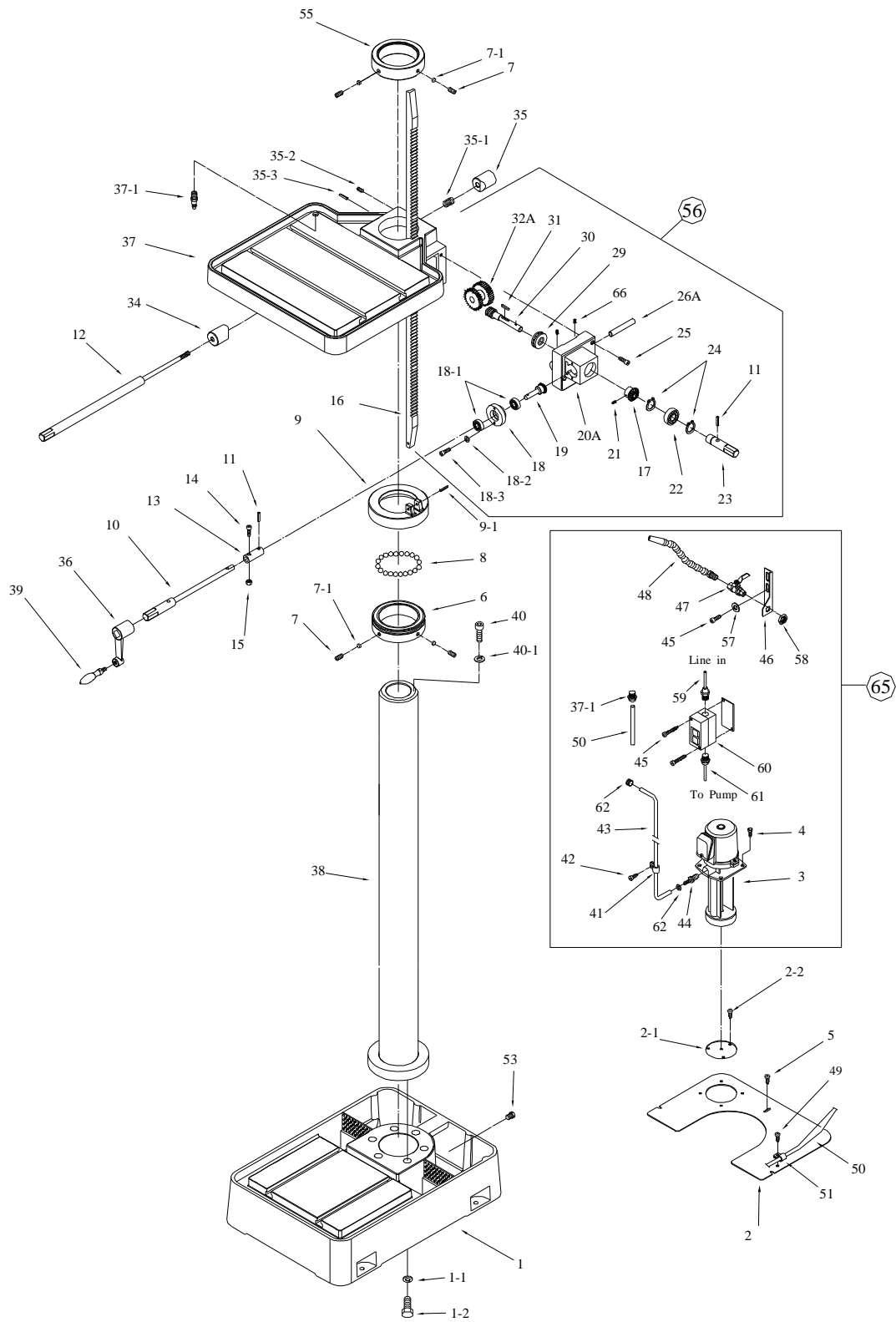

Parts List – Table and Base (All Models)

Index No.	Part No.	Description	Size	Qty
1	J-5510288	Base		1
	J-5510288A	Base (serial no. 7090589 and higher for 2221/2223VS (serial no. 7100425 and higher for 2232/2234AC)		1
1-1	TS-0720111	Lock Washer	1/2"	6
1-2	TS-0070031	Hex Cap Screw	1/2" x 1-1/2"	6
2	J-5510289	Coolant Cover Plate		1
2-1	20EVS-C2-1	Small Cover		1
2-2	20EVS-C4	Screw w/Washer	1/4"	3
3	5510456	Coolant Pump	115V, 1P	1
	5512103	Coolant Pump	220/440V, 3P	1
4	5510291	Hex Bolt		4
5	5517388	Pan Head Screw		3
6	5510293	Ball Seat		1
	5510293A	Ball Seat (serial no. 7090589 and higher for 2221/2223VS (serial no. 7100425 and higher for 2232/2234AC)		1
7	5510294	Set Screw		4
7-1	5517389	Brass Block		4
8	5510295	Ball Bearing		1
9	J-5510296	Lock Ring		1
	J-5510296A	Lock Ring (serial no. 7090589 and higher for 2221/2223VS (serial no. 7100425 and higher for 2232/2234AC)		1
9-1	5517390	Pin		1
10	5516859	Table Raiser Shaft		1
11	5510298	Spring Pin		4
12	5516858	Table Clamp Shaft		1
13	5516860	Table Raiser Coupling		1
14	5510300	Socket Head Screw		1
15	5510301	Nut		1
16	5510302	Rack		1
17	5514663	Large Bevel Gear		1
18	5517391	Bearing Housing		1
18-1	5517392	Ball Bearing	6202ZZ	2
18-2	5517393	Washer		2
18-3	5510303	Cap Screw		2
19	5510304	Small Bevel Gear		2
20	J-5510305	Bracket Cover		1
20A	J-5510305A	Bracket Cover (serial no. 10120276 and higher for J-2221/J-2223VS) (serial no. 11010102 and higher for J-2232AC/J-2234AC)		1
21	5510306	C-Ring		1
22	5510307	Ball Bearing		1
23	5510308	Shaft		1
24	5510309	C-Ring		2
25	5510310	Socket Head Screw		4
26	5510311	Shaft		1
26A	5510311A	Shaft (serial no. 10120276 and higher for J-2221/J-2223VS) (serial no. 11010102 and higher for J-2232AC/J-2234AC)		1
29	5510314	Bearing		1
30	5510315	Table Raise Worm		1
31	5510316	Key		1
32	5510317	Worm Gear		1
32A	5510317A	Worm Gear Assembly (serial no. 10120276 and higher for J-2221/J-2223VS) (serial no. 11010102 and higher for J-2232AC/J-2234AC)		1
34	5510319	Front Cam Lock		1
35	5510320	Rear Cam Lock		1
35-1	5517396	Spring		1
35-2	5517397	Cap Screw	M6x25	1
35-3	5517398	Pin	5x25	2

Index No.	Part No.	Description	Size	Qty
36	J-5510321	Table Raise Crank		2
37	J-5510322	Table		1
37-1	5517399	Hose Coupler (Return)	1/2"	1
38	5510323	Column		1
	5510323A	Column (serial no. 7090589 and higher for 2221/2223VS (serial no. 7100425 and higher for 2232/2234AC)		1
	5510323B	Column with Column Base Assembly (serial no. 14101393 and higher for 2221/2223VS) (serial no. 14100286 and higher for 2232/2234AC)		1
39	5510324	Table Raise Handle		1
40	5510325	Hex Head Screw		1
40-1	5510334	Washer		1
41	5510326	Clamp		1
42	5510327	Pan Head Screw		1
43	5510328	Clear Vinyl Hose	3/8"	1
44	5510329	Hose Coupler (Supply)	3/8"	1
45	5512112	Socket Head Cap Screw	#10-32 x 1"	4
46	5510331	Mounting Bracket		1
47	5510332	Valve		1
48	5510333	Flexible Nozzle		1
49	5517400	Pan Head Screw		1
50	5517401	Clear Vinyl Hose	1/2"	1
51	5517402	Hose Clamp		1
53	5517404	Drain Plug	3/8 NPT	1
55	J-5517406	Rack Collar		1
56	5513932	Table Raiser Assembly		1
57	9057451	Flat Washer	#10	2
58	5517488	Hex Nut	1/2"	1
59	5517489	Power Cord		1
60	5517490	Switch Assembly		1
61	5517491	Pump Cord	1 Phase	1
	5517492	Pump Cord	3 Phase	1
62	5517493	Hose Clamp, Rad. Type		2
65	5512104	Coolant System Complete	1/8 HP, 115/220V, 1 Phase	1
	5508071	Coolant System Complete	1/8 HP, 220/440V, 3 Phase	1
66	TS-1522021	Socket Set Screw	M5 x8	2
	J2221-SBCA	Support Bearing Collar Assembly (includes #6,7,7-1,8,9,9-1)		1

Wiring Diagram – Models J-2221VS and J-2223VS

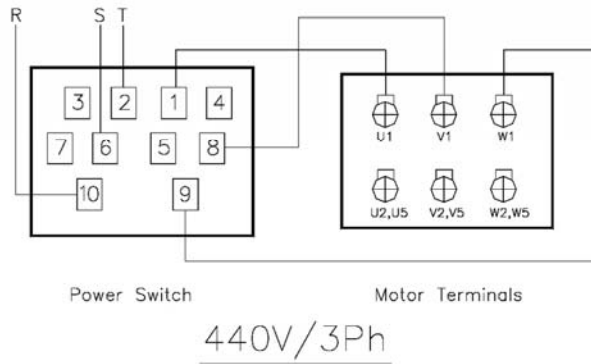
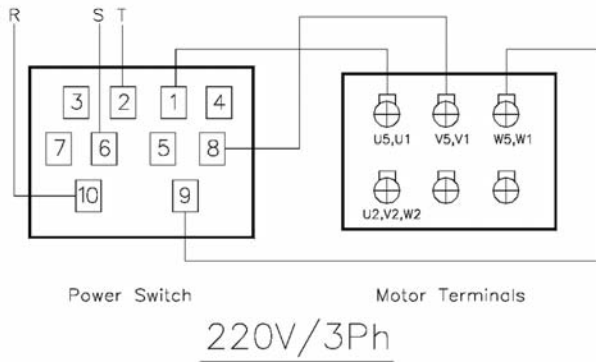
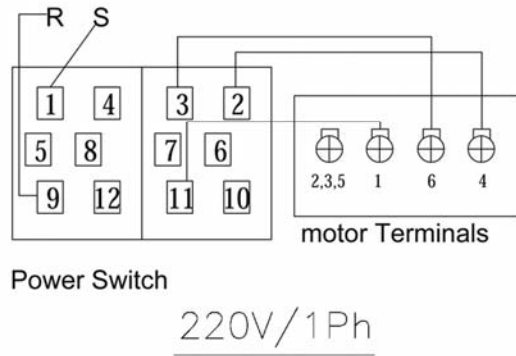
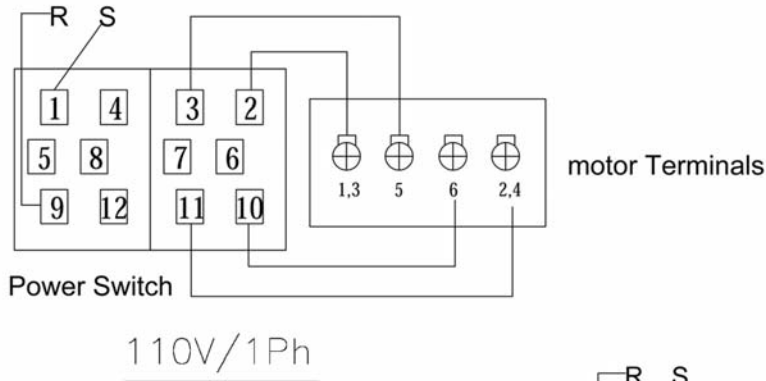

Wiring Diagram – Models J-2232AC and J-2234AC

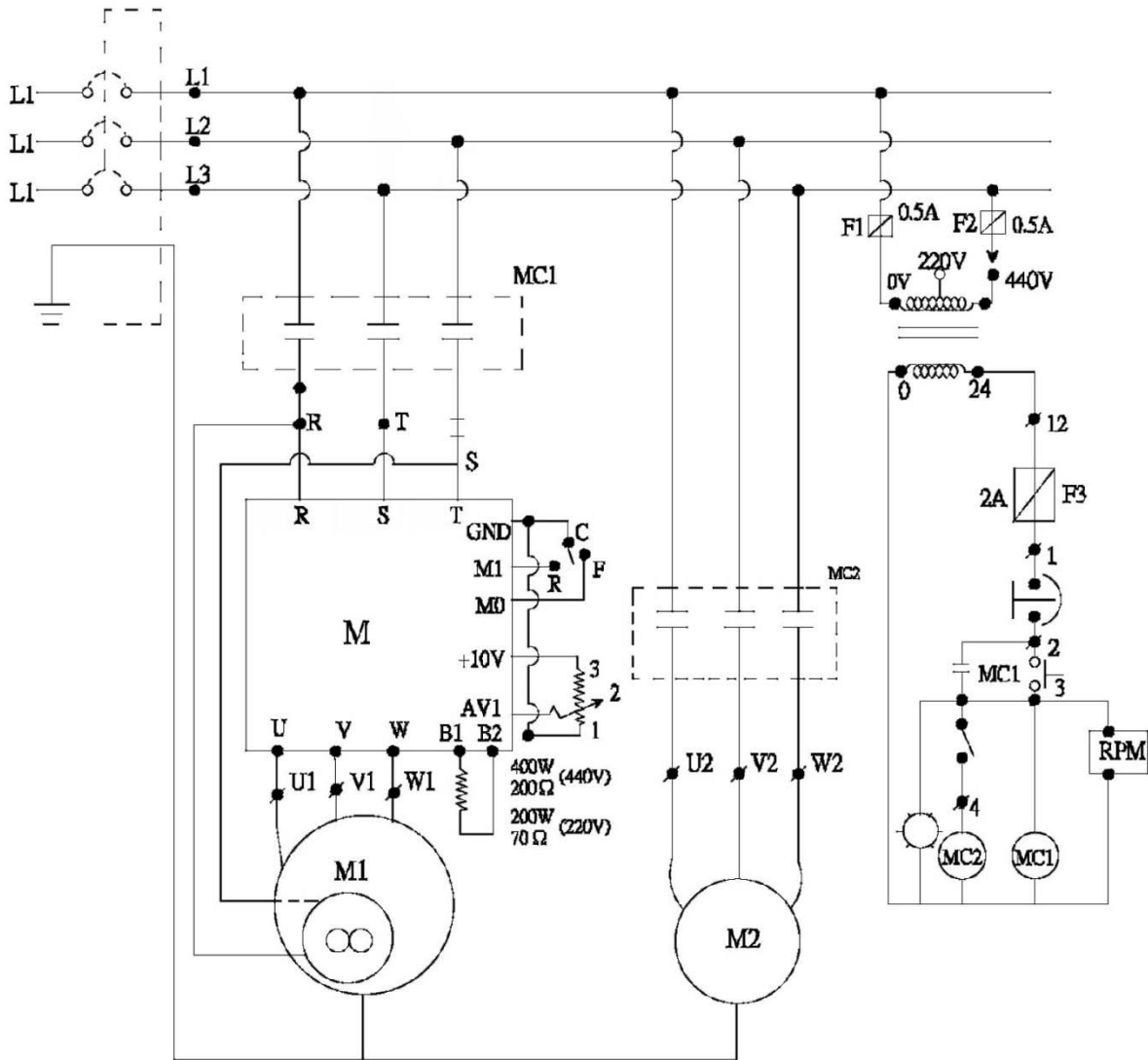

This page intentionally left blank



427 New Sanford Road
LaVergne, Tennessee 37086
Phone: 800-274-6848
www.jettools.com